

Dispute Resolution Services

Adjudication

Adjudication is an adversarial dispute resolution process access to which was provided as a statutory right for those in 'construction contracts' by the 'Housing Grants, Construction and Regeneration Act 1996' ("the Construction Act"). Adjudicator's decisions are binding on the parties at least on an interim basis, that is unless and until a further dispute resolution process is invoked to finally resolve the dispute (arbitration or litigation). Decisions often act as the basis for resolution of all matters on a particular contract.

Whilst the process itself is a matter of common knowledge the necessary experience and the ability to present information in a clear and logical manner and in a way that an adjudicator will understand is a major benefit. Centra has experience in acting as representative of either party in adjudication.

From experience gained Centra is able to provide a valuable service to those involved in adjudication or considering recourse to adjudication to resolve a disputed matter. These services include:

- Centra can carry out an expeditious review of matters to be referred to adjudication and provide advice on the strengths and weaknesses of a case; and
- Centra can provide advice on what, if any, actions need to be carried out prior to commencing adjudication proceedings; and
- Centra can prepare the appropriate notice documentation and referral documentation, or where appropriate response documentation, using experienced personnel; and
- Centra can provide advice throughout the adjudication including expediting the speedy responses required by the fast-track process; and
- Centra can provide representation at adjudication hearings to advance or defend our client's position in the adjudication; and
- Centra can provide advice on how to proceed once the adjudication decision is received; and
- Centra is also able to provide advice on the latest matters affecting adjudication.

Where it is practicable Centra is happy to agree a budget with a client for the proceedings in advance although the extent of input required for some aspects of adjudication, such as those within the control of the adjudicator, are difficult to predict. Alternatively Centra is able to offer a flexible approach to fees to reflect the level of the sum in dispute and is also happy provide an initial 'no obligation' meeting to review potential issues or disputes prior to finalising with client's a course of action and agreeing a strategy.

Centra is also able to act as experts and to provide quantum and delay analysis and forensic planning support to Solicitors and legal teams in adjudication.

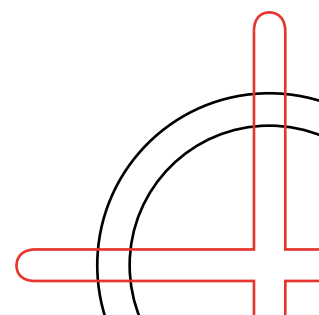

Mediation

Mediation is a non-binding, confidential and without prejudice form of Alternative Dispute Resolution (“ADR”) which is less adversarial in nature than many other forms of ADR. Using experience gained in Mediation Centra is able to offer advice and support or represent a party in this form of ADR.

Mediation is a cost-effective manner in which to resolve disputes and the process can be assisted by the appropriate representation prior to and at a mediation meeting.

Centra can review strengths and weaknesses on issues prior to mediation; advise on the appropriate procedure or mediation agreement/rules; the level of a realistic settlement; preparation of position statements on the case for issue in advance of the mediation; provide support on the day of the mediation whether that be presenting the opening statement or generally providing support; and also assist in the drafting of a settlement agreement if appropriate.

Arbitration

Centra is able to provide support in relation to construction industry disputes being resolved via arbitration. Due to the practical issues being dealt with via the legal process the involvement of experienced construction industry personnel can assist whether this is to do with drafting schedules or pleadings; inspecting documents or interviewing witnesses; or briefing Counsel on technical aspects of the issues.

Litigation

Centra personnel have experience in being appointed to give evidence as expert witnesses. The expert witness service that Centra can offer includes matters in relation to quantum, delay analysis and forensic planning support. Using practical experience Centra is able to provide authoritative and impartial advice to a court or tribunal encompassing many areas of the construction industry.

